

# G3-H01

\* Patents 6,900,603  
6,142,501

## Hydraulic Wireless Control System

### 1 Power-Up, Power-Down Double Acting Solenoid Installation

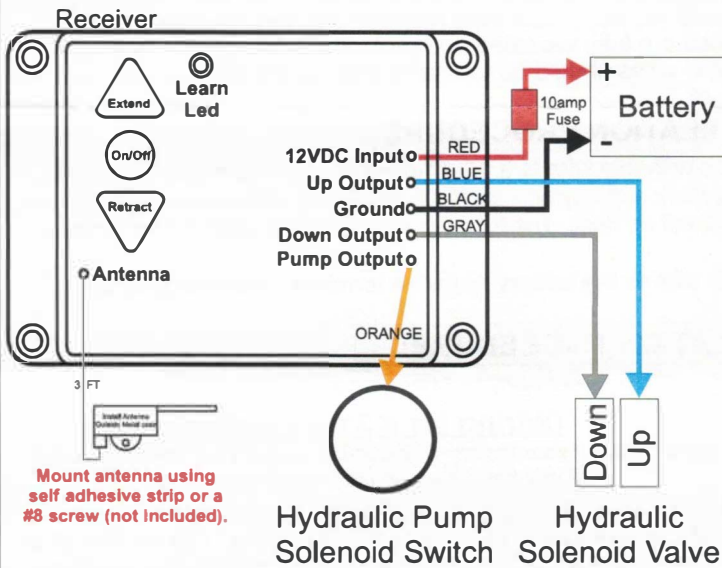

### 2 Power-Up, Power-Down Single Solenoid Installation

With single Hydraulic solenoid installation use either the Blue or Gray only, depending on system.

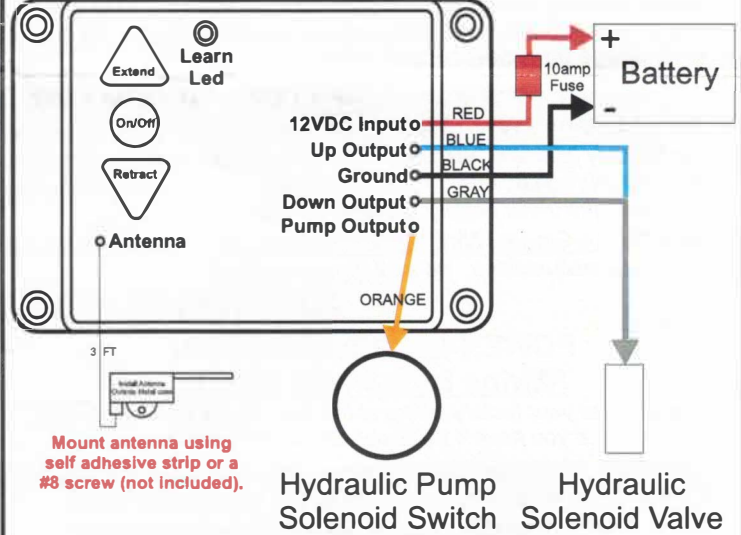

### 3 Power-Up, Gravity-Down Single Solenoid Installation

With single Hydraulic solenoid installation use the Blue and Gray wires only.

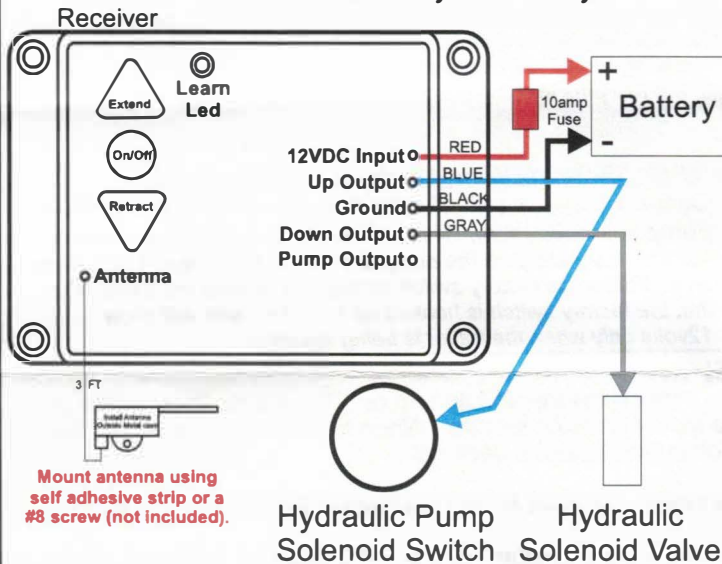

### Function:



When the **Extend** button is depressed the **Orange & Blue** wires are powered with 12VDC.

When the **Retract** button is depressed the **Orange & Gray** wires are powered with 12VDC.

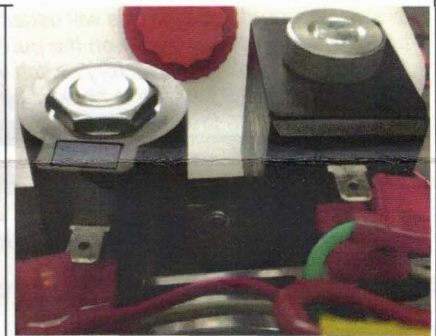
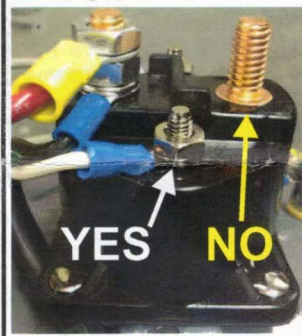

For further assistance, please feel free to contact us.

2905 LaVanture Place • Elkhart, Indiana 46514 USA  
574.262.1258 • FAX 574.264.9138

# G3-H01 Hydraulic Wireless Control System

\* Patents 6,900,603  
6,142,501

The receiver module should be located in an area where the back-up switches will be accessible without the use of the transmitter. Mounting the receiver module within cabinetry works well. **However, if you are mounting the module within a steel compartment it is recommended that you drill a 1/2" hole in the steel, feed the antenna in (screw the end to the Receiver Module), & mount the top of the antenna to the outside of the steel box.**



- Mount antenna using self adhesive strip or a #8 screw (not included).

Typical range with the wireless key fob is 50-100ft, depending on where the receiver module is mounted. The receiver module & transmitter are water resistant. All electrical connections that are made to the control box should be made with properly sized electrical butt connectors. All wiring should be routed in areas that will protect it from road hazards and sharp edges. The receiver module should be installed so that the electrical connections are fully insulated and protected from objects that may come in contact with them causing an electrical short. All connecting wires should be the same size as the wires on the receiver (14/16-gauge stranded copper wire).

## BATTERY WIRING - INSTALLATION PROCEDURE:

- RED 14-Gauge Wire (Main 12volt +dc power)** - Connected in-line with this wire is a **10-amp Fuse**. Connect this red wire to the battery positive terminal. *The fuse is installed within 18" of the battery and may be installed in the battery enclosure or compartment, provided this compartment is well ventilated. This system can handle 12 volt dc input. The Receiver Module's LED will turn from Green to Red when the trailer battery is below 9-volts.*
- BLACK 14-Gauge Wire (Ground 12volt -dc)** - Connect this black wire to the battery negative terminal. *Improper grounding will cause malfunctions. Be sure ground is clean.*

## PUMP WIRING - INSTALLATION PROCEDURE:

### POWER-UP, POWER-DOWN (Wiring for a 4 wire switch)

*Note: Look at your factory wiring at the end of your up/down switch. If you have 4 wires use these instructions.*

- ORANGE 16-Gauge Wire (Common)(12volt for pump up&down)**  
Connect this wire (12volt output) to the trigger side of the pump solenoid switch. *This pin will show 12volts only when the trailer is being raised & lowered. Follow the factory switch wiring. The solenoid is the round part with many wires connected to it. Including the 12volt positive battery cable. It will be the smaller of the two pins that the factory switch wiring is attached to.*
- BLUE 16-Gauge Wire (12volt output to raise trailer)**  
Connect this wire (12volt output) to the UP side of the pump solenoid valve. *This will usually be a square box about 2" square. It's usually on the pump or near it. It will have 1 or 2 wires on it. (If the pump has only 1 square box valve, you have a single solenoid pump. Please disregard this step and skip to terminal #5). Follow the factory switch wiring. Hook up to the same wire that the factory switch is hooked up too. This wire will show 12volts only when the trailer is being raised.*
- GRAY 16-Gauge Wire(12volt output to lower trailer)**  
Connect this wire (12volt output) to the DOWN side of the pump solenoid valve. *This will usually be a second square box about 2" square. It's usually on the pump or near it. It will have 1 or 2 wires on it. Follow the factory switch wiring. Hook up to the same wire that the factory switch is hooked up too. This wire will show 12volts only when the trailer is being lowered.*

### POWER-UP, GRAVITY-DOWN (Wiring for a 3 wire switch)

*Note: Look at your factory wiring at the end of your up/down switch. If you have 3 wires use these instructions.*

- ORANGE 16-Gauge Wire (Common)** - Not used  
*If you have a harness, do not connect this wire. Clip the end off and tape up the end with electrical tape. If this wire touches any metal when unit is activated the unit will short out.*
- BLUE 16-Gauge Wire (12volt output to raise trailer)**  
Connect this wire (12volt output) to the UP side of the pump solenoid switch. *This pin will show 12volts only when the trailer is being raised. Follow the factory switch wiring. The solenoid is the round part with many wires connected to it. Including the 12volt positive battery cable. It will be the smaller of the two pins that the factory switch wiring is attached to.*
- GRAY 16-Gauge Wire (12volt output to lower trailer)**  
Connect this wire (12volt output) to the DOWN side of the pump solenoid valve. *This will usually be a square box about 2" square. It's usually on the pump or near it. It will have 1 or 2 wires on it. Follow the factory switch wiring. Hook up to the same wire that the factory switch is hooked up too. This wire will show 12volts only when the trailer is being lowered.*

## OPERATION:

- Depress the on/off button on the transmitter, to activate. The blue light on the top should turn on. The transmitter should be in the off position when the unit is not in use. This transmitter has a safety time-out feature. When the unit was active and then not used in 1-minute it will automatically turn off. Just hit the on/off button to turn it back on!
- On the transmitter, depress & hold the Extend Button to raise the trailer. Depress & hold the Retract Button to lower the trailer.
- The switch mounted on the receiver module will function the same as the transmitter buttons. The tethered controller, which is usually supplied with the hydraulic pump, will also function to control the hydraulic system. Installation of the tethered system is not required, and can be discarded.

## HOW TO LEARN A TRANSMITTER:

- 1) Enter learn mode: Push & hold the on/off button on the Receiver Module until the LED starts to flash, then release the button
- 2) Push & hold the on/off button on the Transmitter until the LED on the Receiver Module comes on constant. Release the on/off button. The Transmitter is now "learned".
- 3) Option: Learn another transmitter by repeating steps 1 & 2. Note: The Receiver Module exits the "learn mode" after each transmitter is learned. You can learn up to 8 transmitters.
- 4) To clear all transmitters out of the Receiver Module: Push & hold the on/off button on the Receiver Module for 10 Seconds.