

# FEIGHNER ROLLING DOCK ASSEMBLY INSTRUCTIONS

Please Note:

Pipe assemblies are required every 16". For extra stability we recommend pipe assemblies every 8'.

There is an example sketch on the following page.

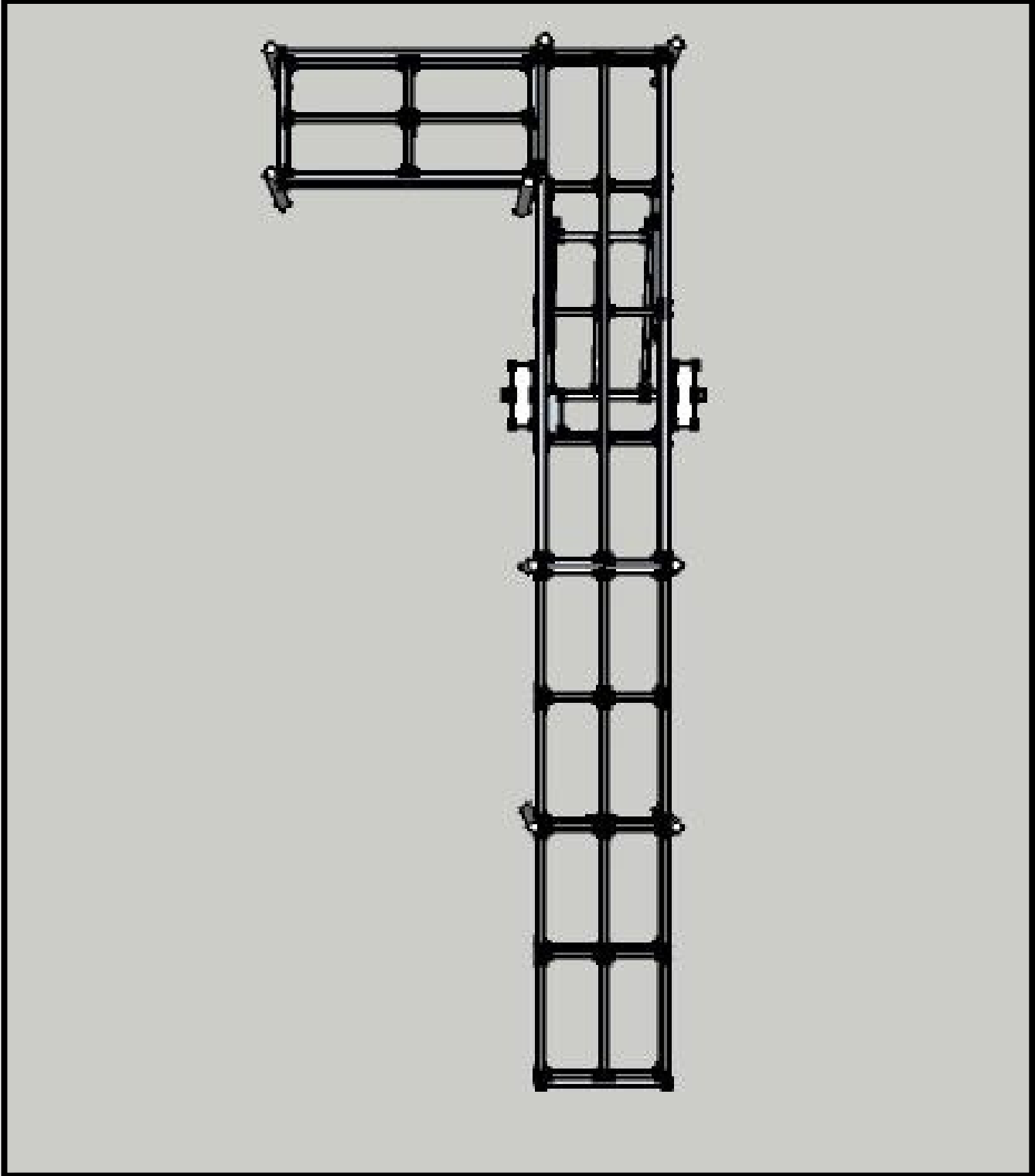
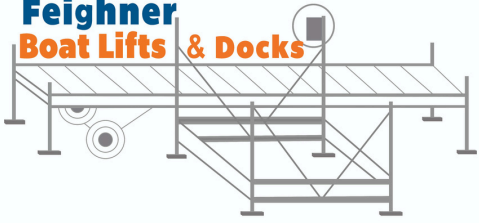

Bolt (2) slide rollers to H Brace assembly using (2) 1/2 x 5" bolts, (6) 1/2" flat washers and (2) 1/2" nuts.

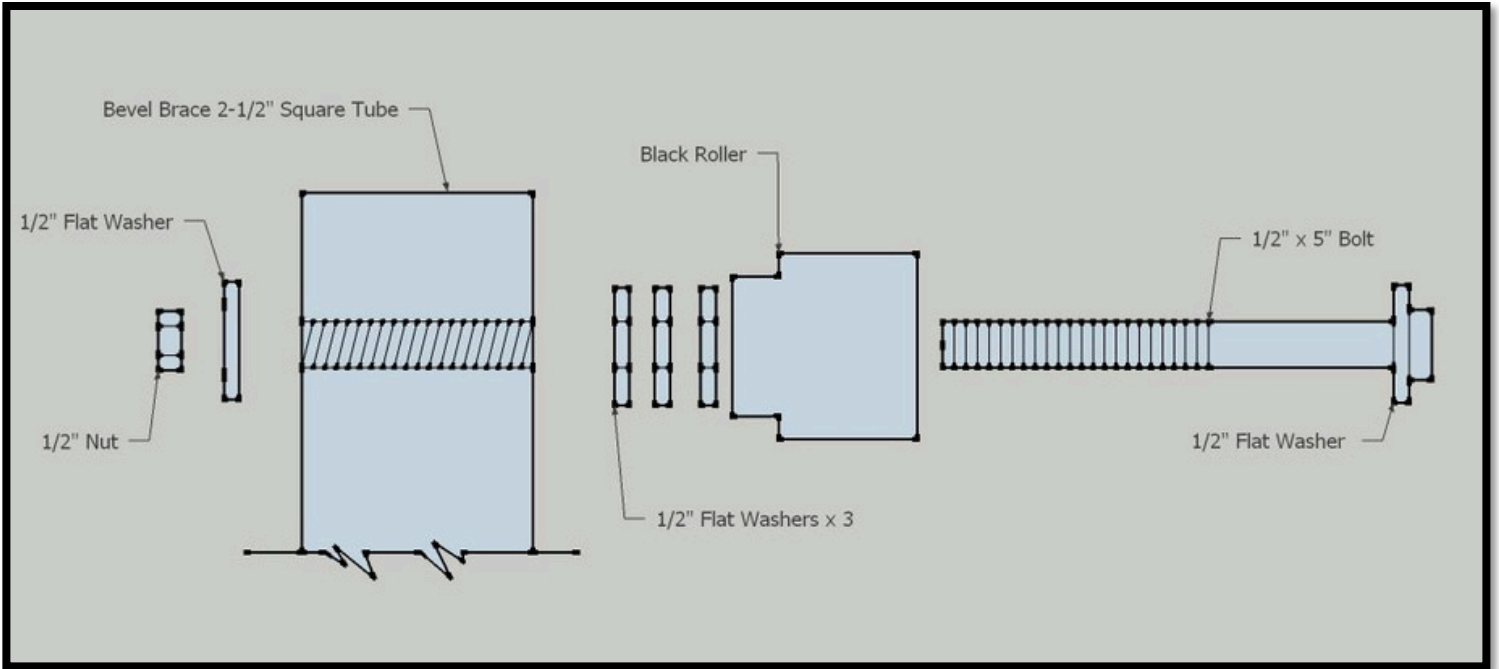

Bolt (2) plastic pulleys to H Brace assembly using (2) 3/8" x 3" Bolts, (4) 3/8" flat washers and (2) 3/8" nuts.

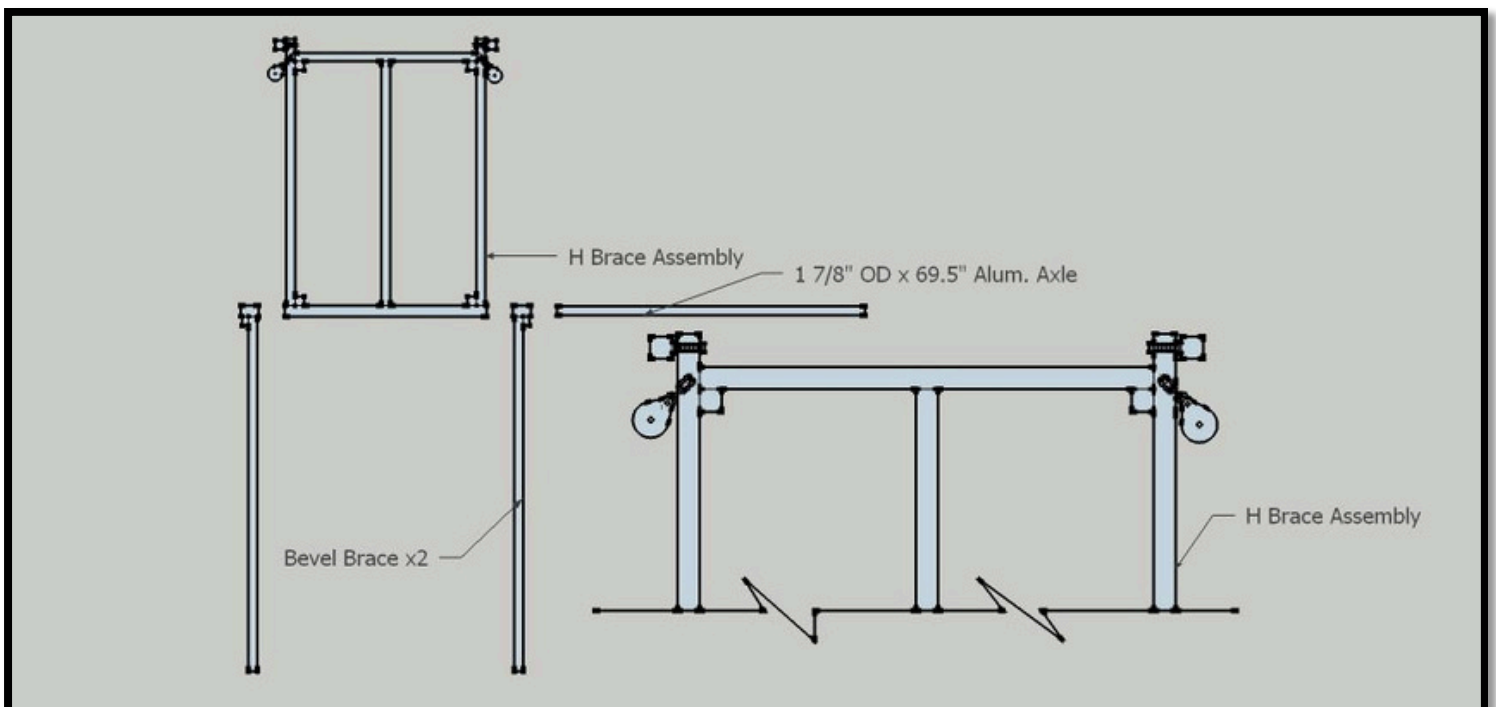



Attach H Brace assembly to 16' Wheel end dock by inserting slide rollers diagonally in slide channels.

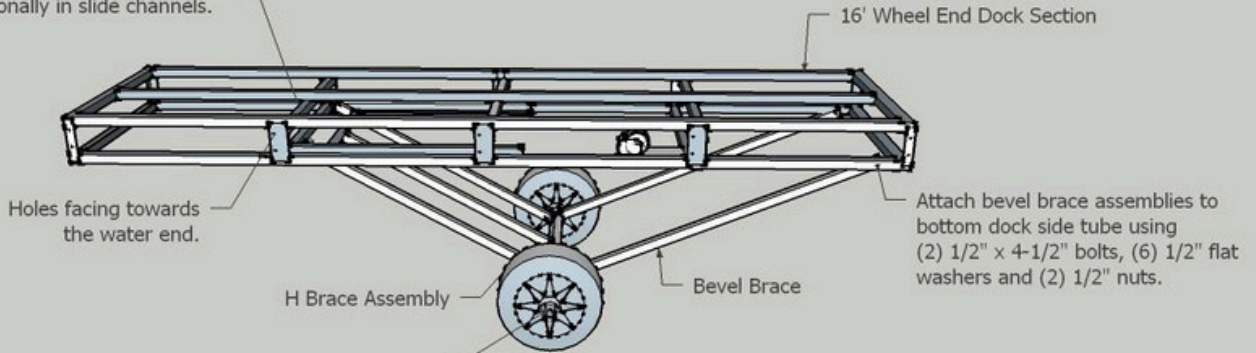

Attach bevel brace assemblies to bottom dock side tube using (2) 1/2" x 4-1/2" bolts, (6) 1/2" flat washers and (2) 1/2" nuts.

After attaching H brace and Bevel braces, slide axle thru the 2-1/2" square tubes of those assemblies.

Attach Winch to the top of winch plate using (2) 3/8" x 1" bolts, (4) 3/8 washers and (2) 3/8" flat washers

Attach 1/4" cable to winch and top cross member using 1/4" clamps

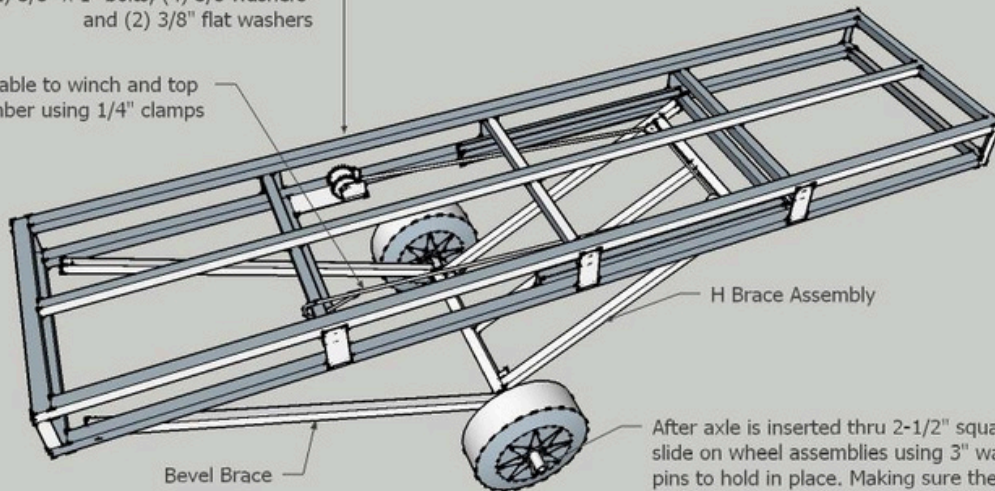

After axle is inserted thru 2-1/2" square tubes, slide on wheel assemblies using 3" washers and 2-1/2" cotter pins to hold in place. Making sure there is a washer on each side of the tire. With the cotter pin being on the very outside of the tire.

## Example of a Pipe assembly

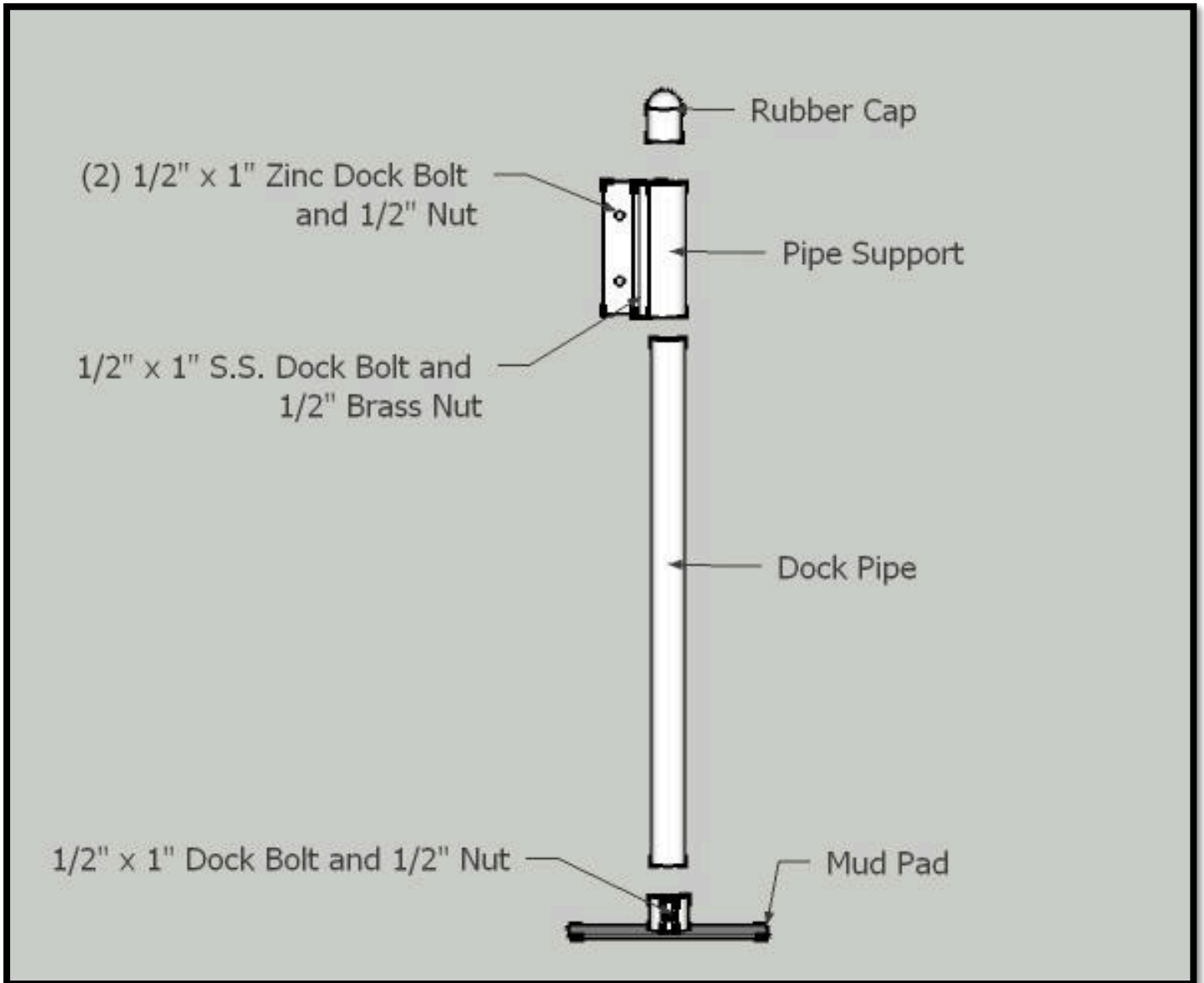

## Assembling the winch

**Before you install the cable to the winch, string the pulleys on to the winch cable first. The 2 – 4 link pulleys first and then the 2 link pulley. Then continue with the assembly of the winch.**

Take the winch bag kit. Take out the “M” Clip with the bolt and nut. Thread the taped end of the cable through the bigger of the two holes. Going from inside the drum to outside. Pull plenty of slack out.

Adding the “M” clip.

On the smaller hole, insert the bolt from within the drum with the bottom side of the bolt through first. So the head of the bolt is on the inside of the drum.

Now add the “M” clip to the bolt with the nut. You will only be able to put the nut on about 3 or 4 threads for now.

See pictures on what direction to thread the cable under the “M” clip.

